

## VCL-TP, Teleprotection Equipment & Trip Counter & Alarm Display Unit

### With 8 Binary Command Inputs and 8 Binary Command Outputs

#### Product Overview:

VCL-TP, Teleprotection / Digital Tele Protection Coupler (DTPC) / Digital Protection Signalling Equipment (PSE) is an extremely reliable and rugged, sub-station hardened equipment that is designed to operate very reliably even under the most demanding conditions and harsh environments. The VCL-TP, Teleprotection Equipment provides up to 8, 2-way independent “binary command” channels which can be operated selectively; or in a combination; or simultaneously over a diverse range of communication interfaces.

VCL-TP, Teleprotection Equipment may be used over E1 (2.048Mbps), over IEEE C37.94 or over Ethernet / IP-MPLS / MPLS-TP links. The VCL-TP, Teleprotection (Protection Signalling Equipment / DTPC) Equipment offers multiple choices of network interfaces which include:

#### Substation interface options include:

- 8 Binary Commands
- IEC-61850 GOOSE (PSCH1 and PSCH2)

#### Network / Transmission interface options include:

- E1 (2.048Mbps)
- 1+1, E1 (2.048Mbps), point-to-point transmission links with path protection / route protection with automatic failover
- Dual E1 (2.048Mbps) transmission links transferring 4+4 Binary Commands over E1 links in a point-to-multipoint application
- IEEE C37.94 Optical link
- Ethernet / IP/MPLS / MPLS-TP (10/100BaseT RJ45; or 100BaseFX Optical) transmission link
- E1 plus IEEE C37.94 Optical, 1+1 redundant transmission links with path protection / route protection with automatic failover
- E1 + Ethernet / IP/MPLS / MPLS-TP (10/100BaseT RJ45; or 100BaseFX Optical) transmission link with path protection / route protection
- E1 plus IEEE C37.94 Optical plus Ethernet / IP/MPLS / MPLS-TP (1+N redundant transmission) links



The “Trip Counter & Alarm Display” unit shows the total number of “Trip Input / Trip Receive” and “Trip Output / Trip Send” commands on each of the 8 Teleprotection channels. A manual display counter reset option is also provided which may be enabled or disabled by the system administrator.

Trip Counter Display and Alarm Extension Unit is designed to function as an optional extension of the Teleprotection Equipment to provide 8 Channels, Digital Trip Counter Display in addition to providing up to 8 External Relay Alarm outputs.

The Trip Counter Display and Alarm Extension Unit may be either powered from the Teleprotection Equipment, or directly from a 48V DC, 110V DC, 220V DC or 250V DC power source. 1+1 Redundant Power is also offered as an option.



#### Command Transfer Time (including relay operating time)

Interface type	Command Transmission Time	Relay Operating Time	Total Command Transfer Time
E1 (2.048 Mbps)	< 2ms	<3ms	<5ms
E1 plus E1 (1+1 redundant)	< 2ms	<3ms	<5ms
IEEE C37.94 Optical	< 2ms	<3ms	<5ms
E1 (2.048Mbps) plus IEEE C37.94 (1+1)	< 2ms	<3ms	<5ms
Ethernet / IP/MPLS / MPLS-TP	< 2ms	<3ms	<5ms
Binary Plus IEC-61850 GOOSE Interface over E1/IEEE C37.94 /Ethernet/IP/MPLS / MPLS-TP	< 2ms	<3ms	<5ms
IEC 61850 GOOSE Over Ethernet/IP/MPLS / MPLS-TP	< 3ms	-	<3ms

#### Features and Benefits:

- Unrivaled Speed, Security and Reliability
- Bi-directional transmission of 8 Binary Command Inputs and 8 Binary Command Outputs
- Dual Direction Teleprotection with Teleprotection Command Distribution
- 8 Channels Trip Counter Display and Alarm Extension Unit
- Compact, standard 19-Inch Rack-mountable chassis
- Full Duplex Operation, Automatic loop test facility
- User programmable to support “Direct Tripping”, “Permissive Tripping” and “Blocking” Protection Schemes. Default “Direct Tripping”.
- Compliant with IEC 60834-1 and all applicable sections of IEC 60834-2 standards
- SNMPv3 management protocol for management and monitoring
- Network interface options:
  - E1, 2.048Mbps; IEEE C37.94 Optical; Ethernet / IP/MPLS / MPLS-TP with 1+1 and 1+n redundant path protection / route protection options
- Substation interface options:
  - 8 Binary Commands
  - IEC-61850 GOOSE (PSCH1 and PSCH2)
- Available in 24 VDC, 48V DC, 110V DC, 220V DC, 250V DC, configurations.

**Smart Grid Ready:**

- May be directly interfaced to IEC-61850 Protection Relays using GOOSE messages (PSCH.1 and PSCH.2)
- Network Interfaces: E1, IEEE C37.94, Optical and IP/MPLS / MPLS-TP Interface Options
- Centralized NMS option for remote monitoring and management of more than 1000 units from central site over an IP network
- Assignable user assigned access levels for configuration and monitoring
- Secure password control
- Encrypted Password Protection
- Maintains logs of all successful and un-successful access attempts
- User programmable “Input” Command sampling time and “Output” Command holding time:
  - Input Sampling Time - Sets the “Sampling Time” of the INPUT Pulse
  - Output Command holding time is the Relay Deactivation Time which sets the duration of the OUTPUT Pulse
- Complies with all relevant Teleprotection Standards and Regulatory Compliances.

**Performance:**

- Less than 2ms command transfer time
- Less than 4ms relay operating time
- Less than 5ms back-to-back operating time (including relay operating time) over IEEE C37.94 Optical Interface
- Less than 5ms back-to-back operating time (including relay operating time) over 2.048Mbps, E1 Interface
- Less than 5ms back-to-back operating time (including relay operating time) over an Ethernet / IP/MPLS / MPLS-TP Interface.

**Flexibility and User Programmability:**

- User programmable input command sampling time for error resistant command inputs
- User programmable output command relay deactivation time.

**Maintenance:**

- **Manual Loop Test:** This feature initiates a “Manual Loop-Test” of the transmission link that interconnects the “Local” Teleprotection Terminal and the “Remote” Teleprotection Terminal.
- **Automatic Loop Test:** The Automatic Link Test feature automatically initiates “Periodic Loop Tests” at user programmed intervals of the transmission link that interconnects the “Local” Teleprotection Terminal and the “Remote” Teleprotection Terminal.
- **Delay Measurement:** This feature automatically initiates an end-to-end “Delay Measurement Test” between the “Local” and the “Remote” Teleprotection Terminal through the interconnecting transmission link.

**Event and Alarm Logging:**

- Time-Stamped Alarm Logging
- Time-Stamped Event Logging
- IRIG-B time synchronization option to synchronize time-stamp with GPS
- NTP time synchronization option to synchronize time-stamp with NTP Server
- IEEE 1588v2 Slave emulation option to synchronize time-stamp with PTP Grandmaster.

**Management and Monitoring:**

- Serial RS232 and USB interfaces for local terminal access
- 10/100BaseT Ethernet Interface for remote access over an IP network
- Encrypted Password Protection
- Telnet - Remote access over IP links
- SSH - Secured remote access using Secure Shell Protocol over IP links
- SNMPv3 Traps and NMS for secure, real time remote monitoring
- Centralised NMS option for remote monitoring and management of up to 1,000 units from central site over an IP network
- Automatic Link Test feature – link testing at user programmable periodical intervals
- Visual I/O status – LED Display
- Dry contact external alarm relay to connect an external alarm on an annunciator panel, which can be wired up for either NO or NC condition.

**Reliability and Dependability:**

- Advanced Communication Protocols to ensure reliable transmission of commands
- Compliant with IEC 60834-1 and all applicable sections of IEC 60834-2 standards
- Power Supply Immunity to withstand impulse surges and transients of up to 10,000 Volts
- High Quality Relays – withstands voltage 10 kV between coil and contacts (1.2 × 50 μps)
- 2.5kV RMS - Contact Input / Output Hi-port dielectric strength
- Maximum Switching Voltage: 400V AC or 300V DC
- Optoisolated Command Inputs
- Optoisolated Relay Outputs
- Relays compliant with IEC-255-0-20 / VDE 0435, 0631, 0700, 40013847 standards
- Relays - Mechanical: 10,000,000 operations min. (at 18,000 operations / hour).

**Technical Specifications:****2.048Mbps, G.703 E1 Interface:**

Number of Interfaces	1
Conformity (Electrical)	G.703 (E1)
Frame Structure	As per ITU (CCITT) G.704
PCM Sampling Rate	8000 Samples/sec
Bit Rate	2048 Kbps ± 50 ppm
Code	HDB3
Nominal Impedance	120 Ohms balanced / 75 Ohms un-balanced (any one option only)
Peak Voltage of a mark For 120 Ohms Balanced interface, 75 Ohms Unbalanced interface	3.0V ± 0.3 V 2.37 V ± 0.237 V
Nominal Pulse Width	244 ns
Pulse Mask	As per ITU (CCITT) Rec. G.703
Output Jitter	< 0.05 UI (in the frequency range of 20Hz to 100 KHz)
Permissible Attenuation	6 dB at 1 MHz
Return Loss at: 51.2 KHz to 102.4 KHz 102.4 KHz to 2048 KHz 2048 KHz to 3072 KHz	> 12dB > 18dB > 14dB
Jitter Tolerance	As per ITU (CCITT) G.823
Loss and recovery of frame alignment	As per clause 3 of ITU (CCITT) G.732
Connector	RJ45 / BNC (only one option)

**Technical Specifications:****C37.94 Optical Fiber Interface**

	Option 1	Option 2
Optical Module Type	SFP	1x9
Connector	LC	ST
Fiber	Multi-mode	Multi-mode
Distance	850 nm, 1310 nm ≤ 500 m, ≤ 2 Km	≤ 2 Km
Type	Laser	LED
IEEE C37.94	Fully Compliant	Fully Compliant

**Ethernet / IP-MPLS / MPLS-TP Interface**

Number of Ports	1 x 10/100BaseT (Copper) Ethernet port OR 1 x 100BaseFX Optical Port
- Electrical	10/100 Auto-negotiation/MDI-X (Auto-sensing), Full-Half Duplex, RJ45 Electrical Connector
- Optical	100Base-FX (Fast Ethernet), SFP
Maximum Frame Size	1500 Bytes

**C37.94 Modulation Compliant Optical Fiber Interface**

Optical Module Type	SFP
Connector	LC
Fiber	Single-mode, 1310 nm, 1550 nm
Distance	≤40 Km, ≤80 Km, ≤120 Km, ≤150 Km
Type	Laser
IEEE C37.94	Modulation Only

**Teleprotection Outputs Commands:**

Maximum Switching Voltage	400V AC or 300V DC
Closing Ability (W/VA)	91W / 1,000VA
Short time current (0.5 sec.)	20A
Crossing a continuous-current (A)	5A
Maximum breaking current at 220V DC	8A
Surge protection arrester module	Built-in / Integrated, MOV Protected @ > 350 V DC

**Teleprotection Inputs Commands:**

Command	48V DC, 110V DC, 220V DC, 250V DC
Minimum Operating Command Voltage	41V DC, 75V DC, 172V DC, 172V DC
Maximum Operating Command Voltage	72V DC, 140V DC, 290V DC, 290V DC
Sense Off	<25V DC, <60V DC, <140V DC, <140V DC
Consumption on a digital input (W)	≤5mA @ 48V DC; <0.24W ≤5mA @ 110V DC; <0.55W ≤5mA @ 220V DC; <1.1W ≤5mA @ 250V DC; <1.25W

**Input / Output Commands Combination Options:**

off	When all 8 inputs are independent
and	When two adjacent inputs are used logically, "and-ed"
or	When two adjacent inputs are used logically, "or-ed"

**Command Transfer Time:**

- Less than 2ms command transfer time

**Relay Operating Time:**

- Less than 4ms relay operating time

**Number of Commands:**

Number of Input Commands	8	Type - Binary
Number of Output Commands	8	Type - Potential Free

**Error Detection and Coding:**

- Link Loss Detection
- LOS Detection
- Line Code Violation Detection
- Block Command Encoding as per IEEE C37.94 (for C37.94 optical links).

**Back-to-Back Switching Time (including command transfer and relay operating time):**

- Less than 5ms back-to-back operating time (including relay operating time) over IEEE C37.94 Interface.
- Less than 5ms back-to-back operating time (including relay operating time) over G.703 E1, 2.048Mbps interface.

**Time Clock:**

- Built-in real time clock (RTC)
- IRIG-B / NTP / IEEE-1588v2 time synchronization options to synchronize the equipment time with an external IRIG-B, NTP or PTP source for accurate event time-stamping.

**Configuration and Access Command Language:**

- Command Line Interface (English text commands).

**Transmission Standards and Compliance:**

- Electrical: ITU-T, G.703 for 2.048Mbps interface
- Optical: IEEE C37.94 compliant Multi-Mode optical interface
- Optical: IEEE C37.94 compliant (modulation only) 1310nm Single-Mode optical interface
- Ethernet / IP / MPLS Interface
  - IEEE-802.3 10/100 Base-T, Auto MDI-X
  - IEEE-802.3u 100 Base-FX Optical
- Laser: Class I (for Single-Mode Optical Interface) - Eye-safe as per EN 60825-1 specifications.

**Teleprotection Standards and Compliances:**

- IEC 60834-1 and IEC 60834-2 (Teleprotection Command Systems)

**Command Voltage Options:**

48V DC	110V DC	220V DC	250V DC
--------	---------	---------	---------

**Power Supply Options:**

- 24V DC, range 18V DC ~ 32V DC
  - 48V DC, range 36V DC ~ 70V DC
  - 110V DC / 125V DC, range 80V DC ~ 140V DC
  - 220V DC / 250V DC, range 80V DC ~ 300V DC
  - 110V AC / 220V AC, range 80V AC ~ 264V AC
- Voltage Withstand: Meets and exceeds IEC 834-1 and IEC 255 requirements.
- Dual / redundant power supply inputs and power supplies are also offered as an option.
  - Short circuit protection
  - Reverse power input protection.

**Power Consumption:**

- < 18 Watts.

**Physical Dimensions:**

Dimensions	Teleprotection Unit	Trip Counter Display
Rack mounting	Standard 19-Inch. DIN Rack	
Height	85 mm / 133mm – standard 2U / 3U high	85 mm. standard 2U high
Depth	298 mm.	240 mm
Width	482 mm.	482 mm
Weight	4 kg	2 kg

**Technical Specifications:**

**Environmental:**

Operating Temperature	-20 C to +60 C
Maximum Operating Humidity	95% R.H., Non-Condensing
Maximum Operating Altitude	Up to 3,000 meters above sea level
Operation	Complies with ETS 300 019 Class 3.2
Storage Temperature	-40 C to +70 C
Storage	Complies with ETS 300 019 Class 1.2
Maximum Storage Humidity	98% R.H., Non-Condensing
Maximum Storage Altitude	Up to 3,000 meters above sea level
Transportation	Complies with ETS 300 019 Class 2.3

**Electromagnetic Standards Compliance:**

- EN 50081-2, EN 50082-2
- IEC 61000-6-2 (immunity)
- IEC 61000-6-4 (emission)
- Complies to IEEE and IEC standards

**CE Compliance:**

- Low Voltage Directive 2014/35/EU
- Electromagnetic Compatibility 2014/30/EU

**Application Diagrams:**

**Typical Point-to-point Application**

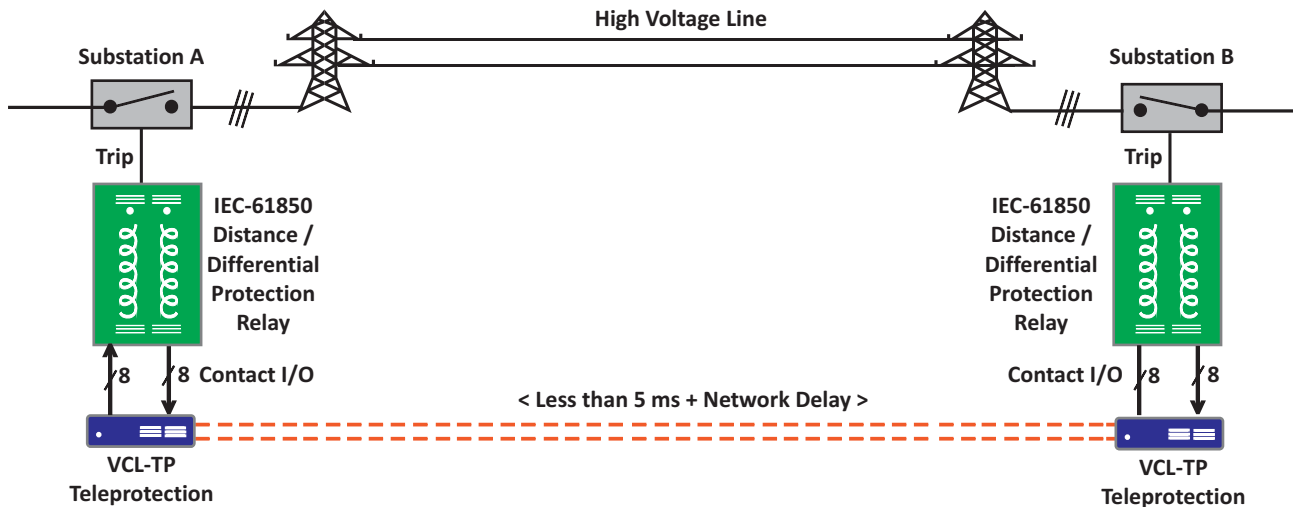

**Teleprotection over SDH / E1 PDH Network**

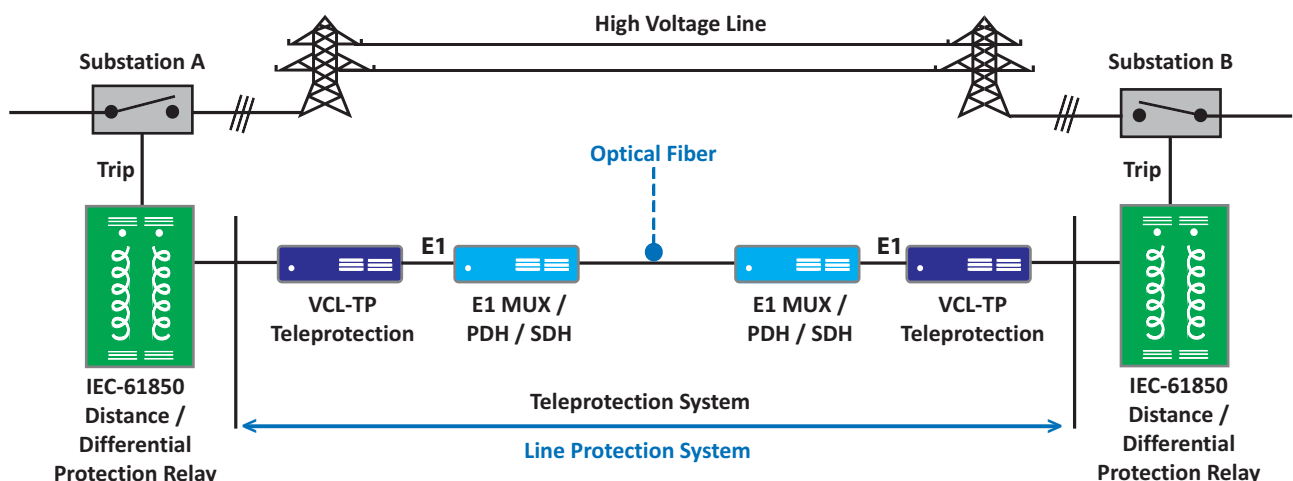

**EMI, EMC, Surge Withstand and other Compliances:**

EN 50081-2	EN 50082-2	IEC 60068-2-29
IEC 61000-4-6 (Conducted Immunity)	IEC 60068-2-6	IEC 60068-2-2
IEC 60068-2-78	IEC 60068-2-1	IEC 60068-2-14
CISPR 22 / EN55022 Class B (Conducted Emission and Radiated Emission)		
IS 9000 (Part II Sec. 1-4, Part III Sec. 1-5, Part IV, Part 14 Sec. 1-3)		
IEC 60870-2-1	IEC 61000-4-5	IEC 61000-4-12
IEC 61000-4-3 (Radiated Immunity)	IEC 61000-4-8	IEC 61000-4-16
IEC 61000-4-2	IEC 61000-4-10	Telcordia GR-1089 Surge and Power Contact
IEC 61000-4-4	IEC 61000-4-11	

- ESD, Voltage and Surge Withstand: Meets and exceeds IEC 61000-4-2, IEC 61000-4-4, IEC 61000-4-5, Level 4 specifications.
- Immunity to Voltage Dips, Short Power Supply Interruptions and Voltage Variations meets and exceeds IEC 61000-4-11, Level 1 specifications.

**Other Regulatory Compliances:**

- RoHS
- CE Marking
- Complies with FCC Part 68 and EMC FCC Part 15
- Telcordia GR-1089 Surge and Power Contact

Teleprotection over E1 (2.048Mbps) Interface

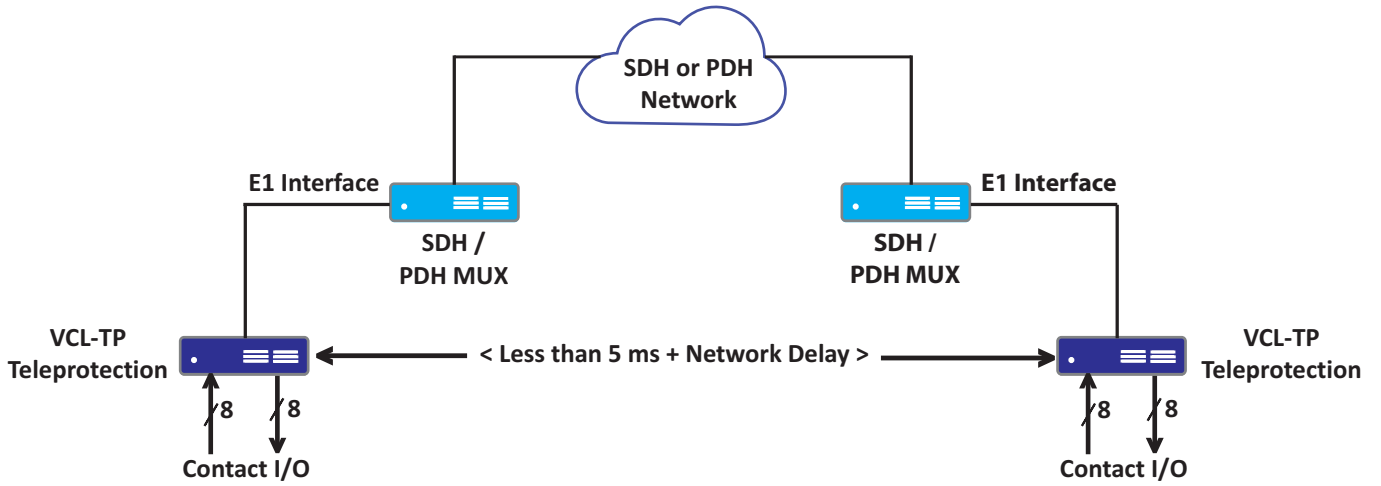

Teleprotection over E1 plus E1 (1+1 redundant) Interface

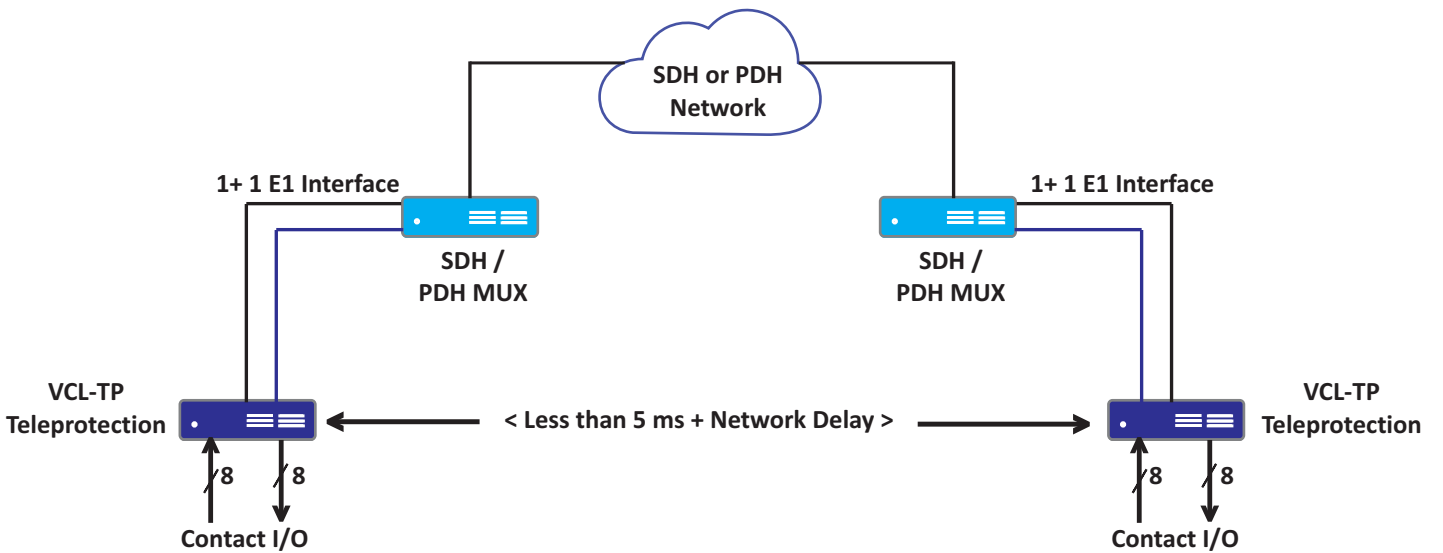

1+1 Redundant E1 interface with link failure detection and automatic failover

Teleprotection over IEEE C37.94 Optical Interface

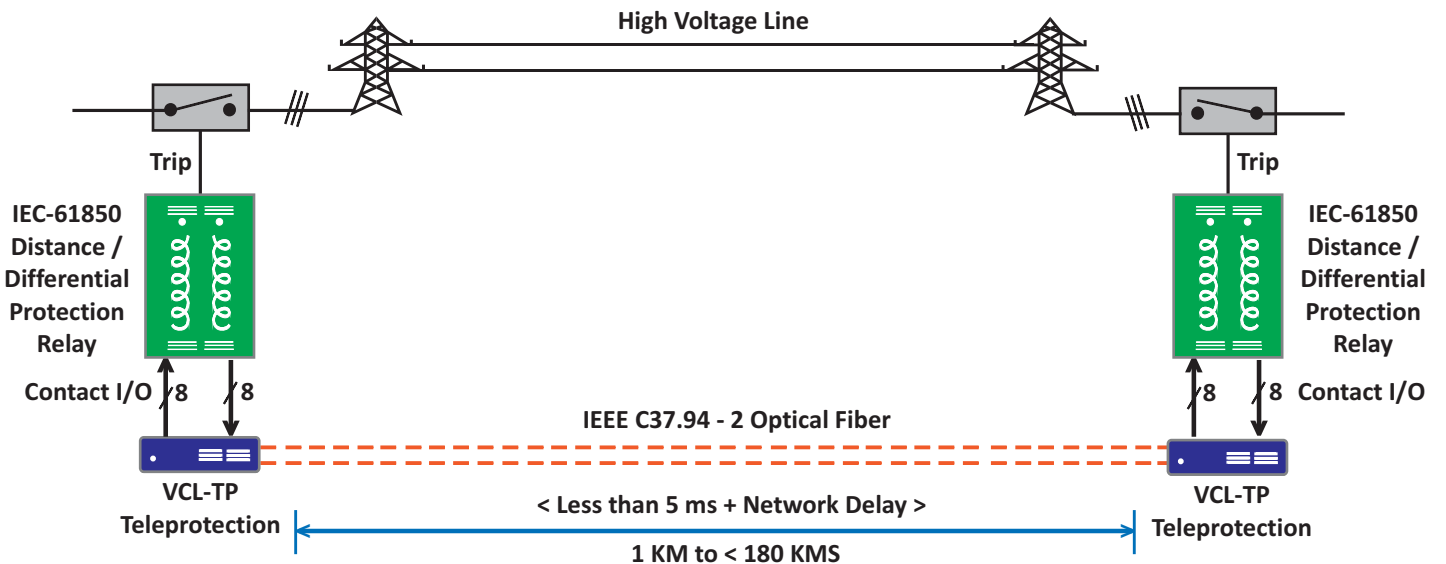

Teleprotection over E1 (2.048Mbps) + C37.94 Interface (Redundant Transmission Links)

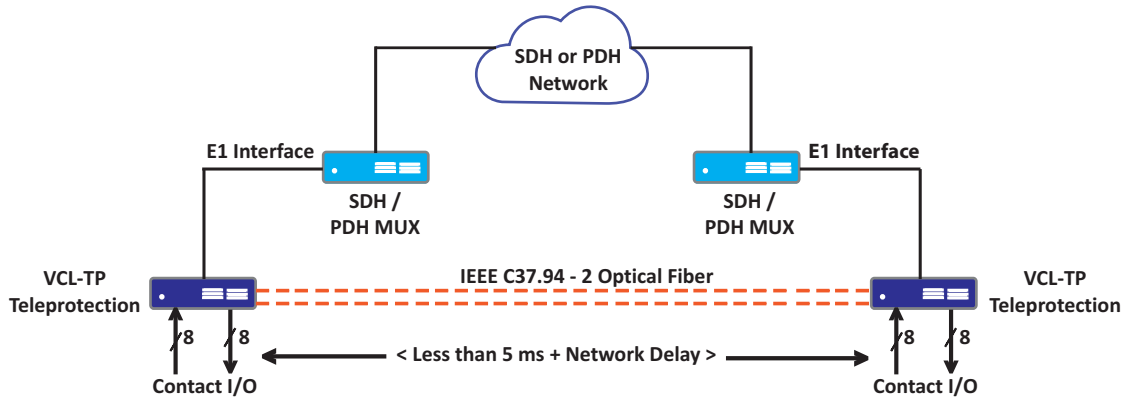

Teleprotection over E1 - Redundant Distance Protection Scheme using "OR" Binary Commands

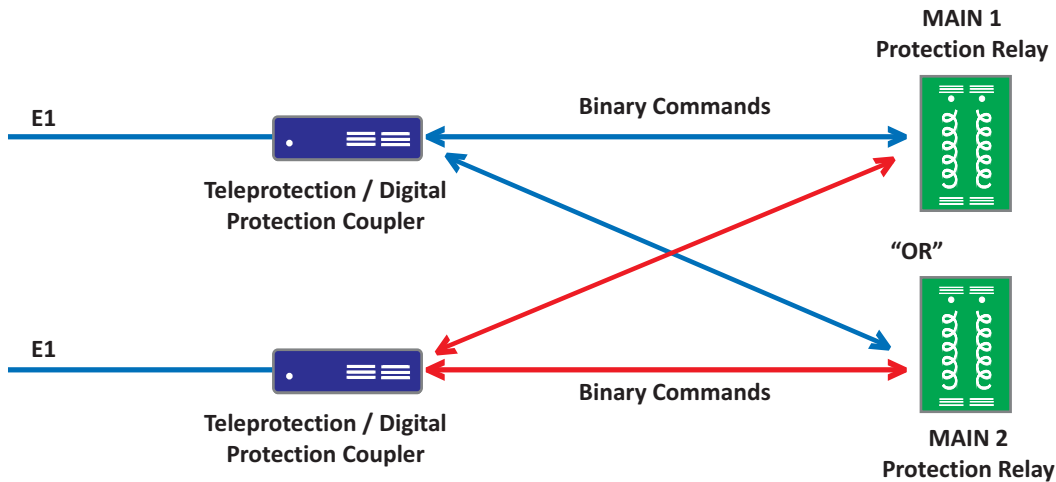

- Note:**
1. This diagram illustrates the scheme in which the MAIN 1 and MAIN 2 relays are connected to E1 Teleprotection equipment (Teleprotection over E1 interfaces) to implement the concept of "Reliable Communications" and provide 1+1 Redundancy for establishing a resilient protection network.
  2. The "OR" function is used to provide alternate tripping paths for both MAIN 1 and MAIN 2 protection relays, to provide fail-safe distance protection.

Teleprotection over C37.94 and E1 - Redundant Distance Protection Scheme using "OR" Binary Commands

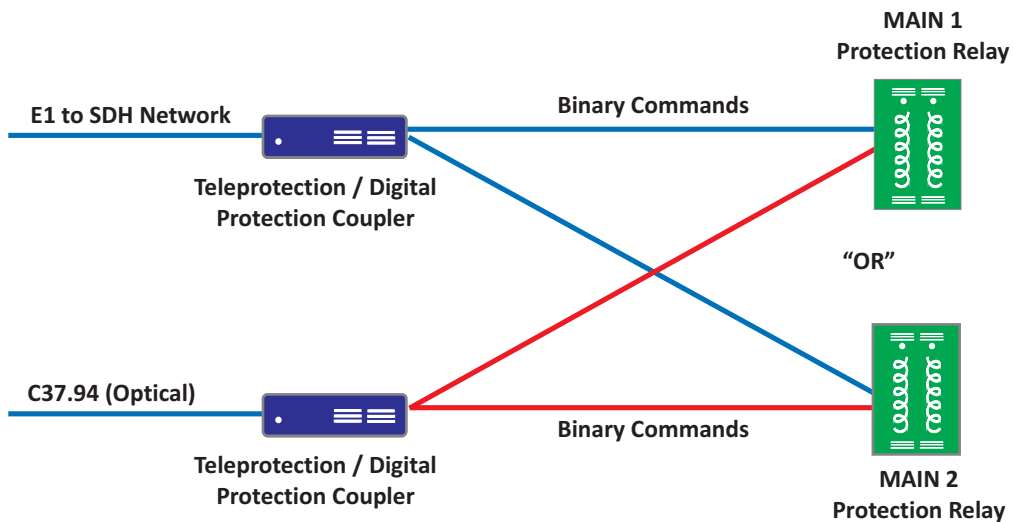

- Note:**
1. This diagram illustrates the scheme in which the MAIN 1 and MAIN 2 relays are connected to provide Teleprotection over C37.94 and E1 Channels to implement the concept of "Reliable Communications" and 1+1 Redundancy for establishing a resilient protection network.
  2. The "OR" function is used to provide alternate tripping paths for both MAIN 1 and MAIN 2 protection relays, to provide fail-safe distance protection.

Distance Protection Reliability Index over E1 plus C37.94 using “OR” Commands.

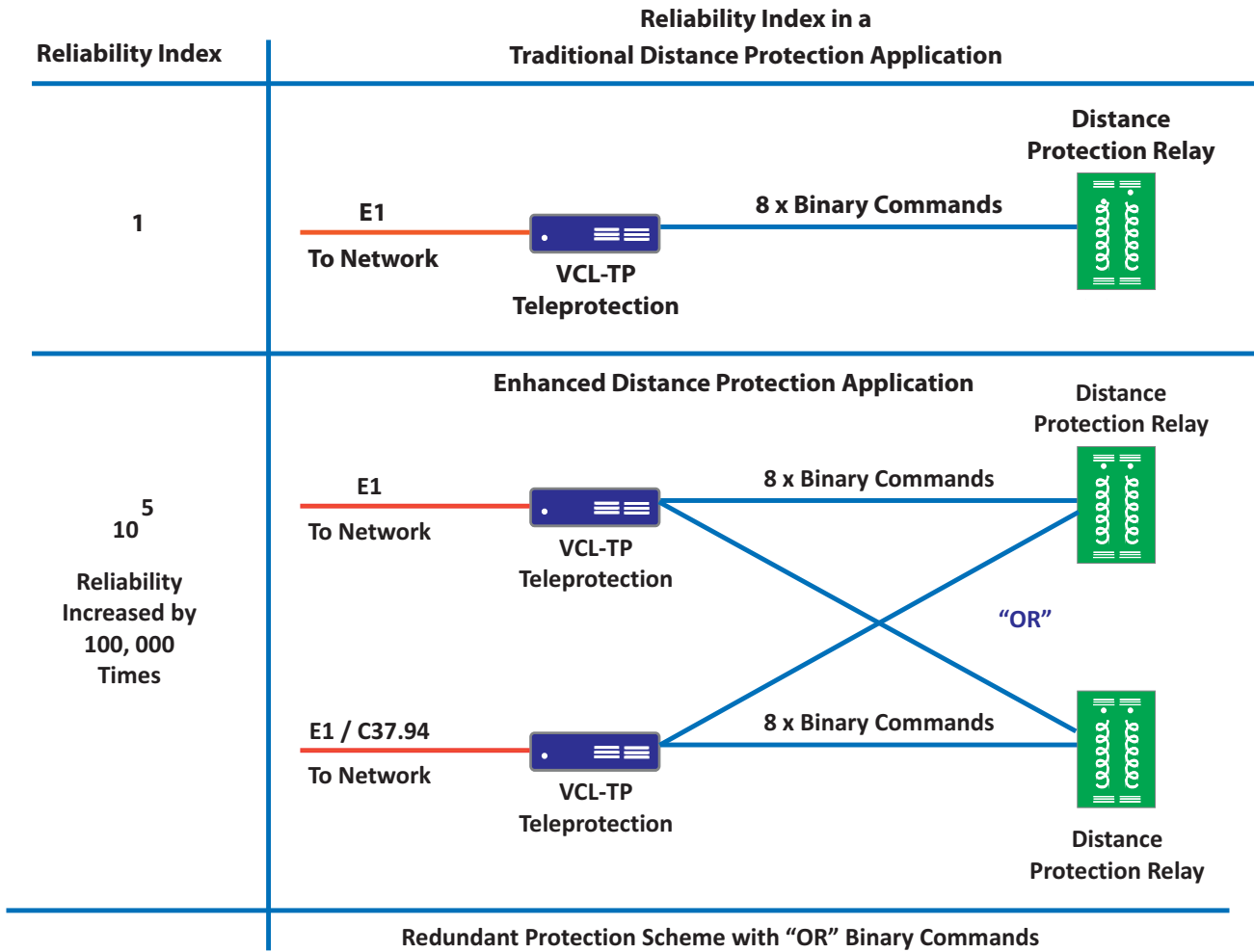

Ordering Information:

BASE UNIT without Network Interface and PSUs:

Part #	Description
VCL-TP-1531	VCL-TP, TeleProtection Terminal Equipment 19-Inch, Rack mountable - Management: SNMP/Telnet Port (RJ45 (F)), Serial Port (USB, DB-9 COM), Serial Port, EMS, Graphical User Interface (GUI) - Installation Kit: System Core Cables, Mounting Hardware, Documentation, User Manual  Substation Interface: BINARY - 8, 2-way independent binary commands  Network Interfaces: [# Add Network Interface]  [# Add Power Supply] [# Select / Specify Command Voltage] [# Add Trip Counter Display (optional)]

# Specify Command Voltage (Any One Option)

Part #	Description
CV024048	Command Voltages: 16-24V DC / 38-48V DC
CV048110	Command Voltages: 38-48V DC / 110V-125V DC
CV110220	Command Voltages: 110-125V DC / 220-250V DC

# Add Power Supply Option (Any One Option)

Part #	Description
AC220	1 x 110~240V AC Power Supply Input
AC220R	2 x 110~240V AC Power Supply Input [Redundant]
DC048	1 x 48V DC Power Supply Input
DC110	1 x 110V~125V DC Power Supply Input
DC220	1 x 110V~250V DC Power Supply Input
DC048R	2 x 48V DC Power Supply Input [Redundant]
DC110R	2 x 110V~125V DC Power Supply Input [Redundant]
DC220R	2 x 110V~250V DC Power Supply Input [Redundant]

## # Add Network Interface (Any one option)

Part #	Description
2715-2730-2733-O	1 x C37.94 protocol optical interface [without SFP]
2715-2730-2733-E1O	1+1 redundant, automatic protection E1 Plus C37.94 interface - 1 x 2.048Mbps E1 (120 Ohms) digital interface [RJ45 (F)] - 1 x C37.94 protocol optical interface [without SFP]
2715-2730-2734-O	1 x C37.94 protocol optical 820nm, (MM, TX/RX, ST) interface
2715-2730-2734-E1O	1+1 redundant, automatic protection E1 Plus C37.94 interface - 1 x 2.048Mbps E1 (120 Ohms) digital interface [RJ45 (F)] - 1 x C37.94 protocol optical 820nm, (MM, TX/RX, ST) interface
2715-2730-2736-1E1	1 x 2.048Mbps E1 (120 Ohms) digital interface [RJ45 (F)]
2715-2730-2736-2E1	1+1 redundant, automatic protection E1 interface - 2 x 2.048Mbps E1 (120 Ohms) digital interface [RJ45 (F)]
2715-2730-2736-2E1-PMP	- 2 x 2.048Mbps E1 (120 Ohms) digital interface [RJ45 (F)] (Point-to-multipoint)
2715-2714-2733-E1O-IP	1+1 redundant, E1 Plus C37.94 Plus IP interface with automatic 1+N failover protection E1 Interface - 1 x 2.048Mbps E1 (120 Ohms) interface [RJ45 (F)] C37.94 Interface - 1 x C37.94 protocol optical interface [without SFP] Ethernet / IP / MPLS Interface - 1 x 10/100BaseT Electrical Ethernet Port [RJ45 (F)] - 1 x 100BaseFX Optical Ethernet Port [without SFP]
2715-2714-2736-1E1-IP	E1 Plus Ethernet / IP interface with automatic failover protection E1 Interface - 1 x 2.048Mbps E1 (120 Ohms) interface [RJ45 (F)] Ethernet / IP / MPLS Interface - 1 x 10/100BaseT Electrical Ethernet Port [RJ45 (F)] - 1 x 100BaseFX Optical Ethernet Port [without SFP]
2715-2714-2736-2E1-IP	1+1 E1 Plus Ethernet / IP interface with automatic failover protection E1 Interface - 2 x 2.048Mbps E1 (120 Ohms) interfaces [RJ45 (F)] Ethernet / IP / MPLS Interface - 1 x 10/100BaseT Electrical Ethernet Port [RJ45 (F)] - 1 x 100BaseFX Optical Ethernet Port [without SFP]
2715-2714-2736-1E1-IP-GOOSE	E1 Plus Ethernet / IP interface with automatic failover protection E1 Interface - 1 x 2.048Mbps E1 (120 Ohms) interface [RJ45 (F)] Ethernet / IP / MPLS Interface - 1 x 10/100BaseT Electrical Ethernet Port [RJ45 (F)] - 1 x 100BaseFX Optical Ethernet Port [without SFP] IEC-61850 - GOOSE ( <b>Substation Interface</b> ) - 1 x 10/100BaseT Electrical Ethernet Port [RJ45 (F)]
2715-2714-2736-2E1-IP-GOOSE	1+1 E1 Plus Ethernet / IP interface with automatic failover protection E1 Interface - 2 x 2.048Mbps E1 (120 Ohms) interfaces [RJ45 (F)] Ethernet / IP / MPLS Interface - 1 x 10/100BaseT Electrical Ethernet Port [RJ45 (F)] - 1 x 100BaseFX Optical Ethernet Port [without SFP] IEC-61850 - GOOSE ( <b>Substation Interface</b> ) - 1 x 10/100BaseT Electrical Ethernet Port [RJ45 (F)]
2714-2154	IEC-61850 - GOOSE over IP / MPLS - 2 x 10/100BaseT Electrical Ethernet Port [RJ45 (F)] - 1 x 100BaseFX Optical Ethernet Port [without SFP]
2432-1546	IEC-61850 - GOOSE over E1 - 1 x 10/100BaseT Electrical Ethernet Port [RJ45 (F)] - 1 x 100BaseFX Optical Ethernet Port [without SFP] - 1 x 2.048Mbps E1 (120 Ohms) digital interface [RJ45 (F)]
E1-120-75-CONV	E1 120 Ohms (RJ45) to E1 75 Ohms (BNC) Converter



## Ordering Information

### # Select SFP Option (1 SFP per UNIT):

Part #	Description
VCL-EMOD 0469-TP	SFP Transceiver, Duplex LC, 14dB, 820nm, 1 Mile / 2Km, MM (Multi-Mode)
VCL-EMOD 0193-TP	SFP Transceiver, Duplex LC, 13dB, 1310nm, 9 Miles / 15Km, SM (Single-Mode)
VCL-EMOD 0194-TP	SFP Transceiver, Duplex LC, 29dB, 1310nm, 25 Miles / 40Km, SM (Single-Mode)
VCL-EMOD 0217-TP	SFP Transceiver, Duplex LC, 29dB, 1550nm, 49 Miles / 80Km, SM (Single-Mode)
VCL-EMOD 0402-TP	SFP Transceiver, Duplex LC, 37dB, 1550nm, 99 Miles / 160Km, SM (Single-Mode)
VCL-EMOD 0171-TP	SFP Transceiver, Duplex LC, 46dB, 1550nm, 111 Miles / 180Km, SM (Single-Mode)
VCL-EMOD 0244-TP	SFP Transceiver, Duplex LC, 47dB, 1550nm, 124 Miles / 200Km, SM (Single-Mode)
VCL-EMOD 0364-TP	SFP Transceiver, Duplex LC, CWDM, 46dB, 1550nm, 161 Miles / 260Km, SM (Single-Mode)
VCL-EMOD 0490-TP	SFP Transceiver, Duplex LC, CWDM, 50dB, 1550nm, 167 Miles / 270Km, SM (Single-Mode)

### # Add VCL-TP external feed-through terminal block panel optional, if required

Part #	Description
VCL-HTER 1030-60IO	VCL-TP external feed-through Knife disconnect Terminal Block (TB) 60-I/O (2 x input and 2 x output) 19" 2U High Rack Mount Version
VCL-HRNS 1294-08-01.00M	8-Point, Feed-through Cable (8PINF/RA/Screw Flange to open), 1 meter] [4 cables required to order]
VCL-HRNS 1294-04-01.00M	4-Point, Feed-through Cable (8PINF/RA/Screw Flange to open), 1 meter) [2 cables required to order]
VCL-HRNS 1294-03-01.00M	3-Point, Feed-through Cable (5PINF/RA to open), 1 meter) [2 cable required to order]

### # Add Trip Counter Display (External Trip Counter Display) – optional, if required

Part #	Description
VCL-DISP-1599- 1597-08-DC048	Trip Counter Display / Alarm Extension Unit – 16 x Trip (8 Input and 8 Output) Counter Display – 8 x User Assignable External Relay Alarm outputs 19-Inch, 2U High Rack mountable – 1 x (-) 48V DC Power Supply Input
VCL-DISP-1599- 1597-08-DC048R	Trip Counter Display / Alarm Extension Unit – 16 x Trip (8 Input and 8 Output) Counter Display – 8 x User Assignable External Relay Alarm outputs 19-Inch, 2U High Rack mountable – 2 x (-) 48V DC Power Supply Inputs

### Optional - Trip Counter Display Panel and Alarm Extension Unit:

- The Trip Counter Display Panel and Alarm Extension Unit can be installed in conjunction with the Teleprotection unit to display the count of the “Trip Input Sense” and “Trip Output Initiate” events and to obtain and extend additional alarm outputs to the Sub-Station “Alarm Annunciator” panel.
- 16, (8 Inputs and 8 Outputs) Trip Counter Display Panel to display the count of the “Trip Input Sense” and “Trip Output initiate” events
- Additionally provides 8 user configurable external dry contact alarm outputs to extend up to 8, separate user assignable alarms
- Each alarm output can be individually assigned to any type of event, including failure of Transmission Link, PSU Failure Alarm, Trip Input Sense / Trip Output Initiate Commands.

**Note:** The Trip Counter Display and Alarm Extension Unit may, or may not be ordered with the Teleprotection Equipment, depending upon the user requirements.

Technical specifications are subject to changes without notice.  
Revision – 6.7, July 27, 2022

**U.K.**  
Valiant Communications (UK) Ltd  
Central House Rear Office  
124 High Street, Hampton Hill  
Middlesex, TW12 1NS, U.K.  
**E-mail:** gb@valiantcom.com

**U.S.A.**  
Valcomm Technologies Inc.  
4000 Ponce de Leon Blvd.,  
Suite 470, Coral Gables,  
FL 33146, U.S.A.  
**E-mail:** us@valiantcom.com

**INDIA**  
Valiant Communications Limited  
71/1, Shivaji Marg,  
New Delhi - 110015,  
India  
**E-mail:** mail@valiantcom.com