



VCL-MegaConnect™ 32 Port Plus - T1 Monitoring Groomer

Product Brochure & Data Sheet

U.K.

Valiant Communications (UK) Ltd
Central House Rear Office
124 High Street, Hampton Hill
Middlesex, TW12 1NS, U.K.
E-mail: gb@valiantcom.com

U.S.A.

Valcomm Technologies Inc.
4000 Ponce de Leon, Suite 470
Coral Gables,
FL 33146, U.S.A.
E-mail: us@valiantcom.com

INDIA

Valiant Communications Limited
71/1, Shivaji Marg,
New Delhi - 110015,
India
E-mail: getinfo@valiantcom.com

Introduction

The VCL-MegaConnect™ 32 Port Plus - T1 Monitoring Groomer is suitable for non-intrusive monitoring of up to 16, bi-directional "live" T1 traffic links (i.e. in both transmit and receive directions) through its 32 T1 receivers. The Groomer is capable of receiving the "monitored" T1 signal inputs through the high impedance (Hi-Z) path of a patch-panel, without in any way disturbing the "live" T1 traffic links. The Groomer provides the "user" the facility to cross-connect 64Kbps time-slots through a completely "non-blocking" TSI switch, through which the selected SS7 signaling time-slots on the INPUT side T1 Ports can be connected to the OUTPUT side T1 Ports. The equipment provides 4 T1 Ports on the OUTPUT side from where the selected / cross-connected / aggregated SS7 time-slots may be connected to the protocol analysers, test probes, etc.



Description

The VCL-MegaConnect™ 32 Port Plus - T1 Monitoring Groomer, occupies only a 2U high rack-space and is a compact 19-inch stand-alone unit. The unit is powered by and operates on a -48V DC power supply. An AC mains option is also available with an external AC-DC converter.

The equipment is provided with BOTH, RS232 Serial Interface for COM Port connection and as well as a TCP/IP LAN Interface (10/100BaseT) for providing equipment access through Telnet over a TCP/IP link. The user may select and use either of these ports for executing HyperTerminal text commands for configuration etc. The access for configuration and system management is provided through CLI (Command Line Interface) text commands which may be executed either from a serial (COM) Port of a PC or through the 10/100BaseT LAN Interface. The 10/100BaseT LAN Interface allows the equipment to be connected on a TCP/IP network for remote access for configuration and monitoring over LAN and TCP/IP link. The system is also supplied with an easy to use Windows (Windows XP, Windows 7) Graphical User Interface that provides the user a complete control to prepare multiple configuration "maps" and store them, as easy to read data files. Dry contact relay alarm output is also available at rear of the system to connect the system to an external audio/visual alarm output through a dry relay contact.

The T1 Groomer is capable of non-intrusively monitoring upto 16 "live" T1 links and grooming the selected 64 Kbps time-slots to the 4 additional output T1 Ports provided in the equipment. The 32, T1 receivers of the Groomer shall connect to the 16, T1 "live traffic" links which are to be monitored, non-intrusively. 4 additional (Normal-Z) output T1 Ports are also provided by the equipment which shall route the aggregated data of the "monitored" time-slots to the user's test equipment, such as protocol analysers, test probes, billing servers etc.

The T1 Groomer (T1 Monitoring DACS) is capable of monitoring a -20dBx (0.3Volt Pulse) T1 signal through a Hi-Z path, without in any way affecting or disturbing the "live" T1 traffic that is required to be monitored.

The equipment offers the user with complete flexibility to choose and select time-slots from each of the 16 T1 links that are being monitored, without limitation or restrictions, through the internal TSI non-blocking switch (data received by the equipment's 32 T1 receivers) and then aggregate the selected time-slots to the 4 output T1 ports that shall connect to the test probes etc.

Application Diagram

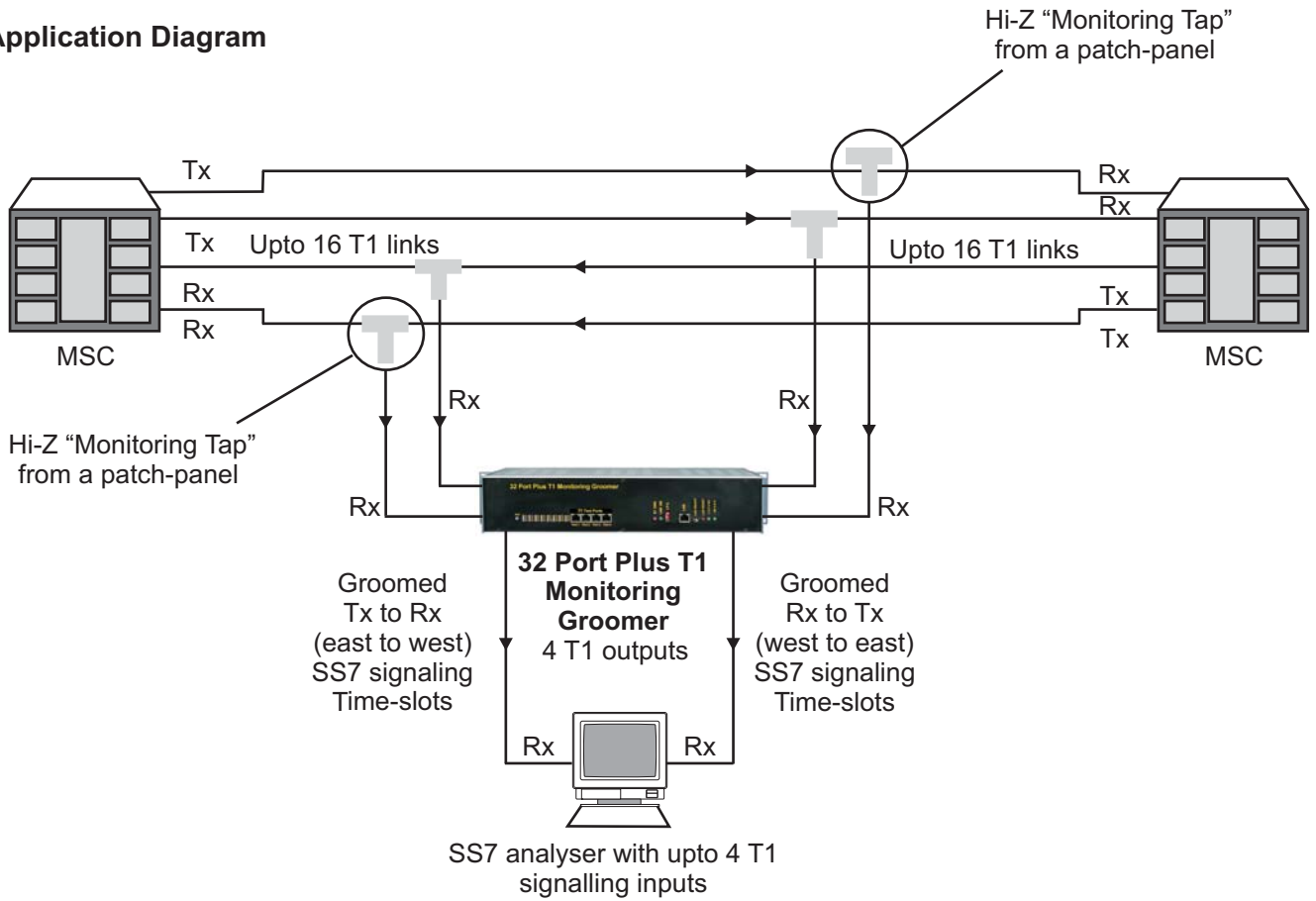

Note: The T1 link is "tapped" through a Hi-Z "Tapping" Port of a DDF Patch Panel.

Non-Intrusive Monitoring Application

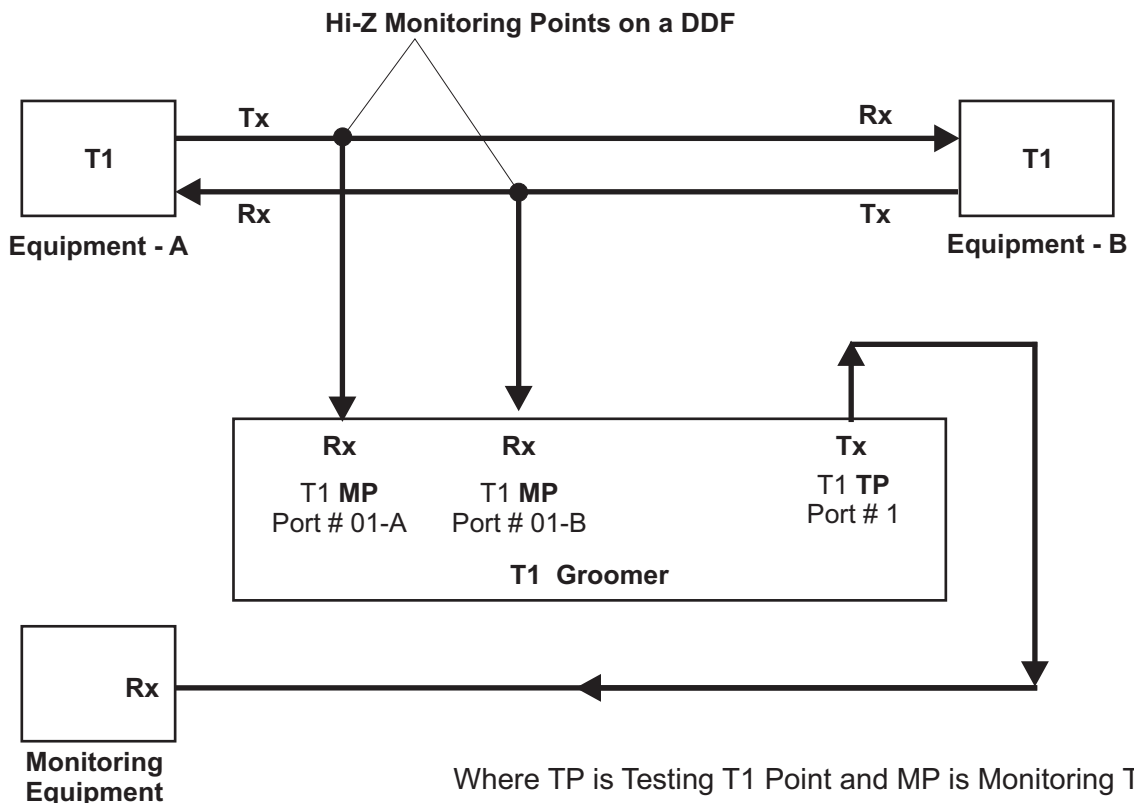

Where TP is Testing T1 Point and MP is Monitoring T1 Point.

Shelf Description

The VCL-MegaConnect™ 32 Port Plus - T1 Monitoring Groomer unit is a 2U, 19 Inch Shelf, fitted with a backplane that provides rear access of all external interfaces. The T1, 1.544 Mbps electrical I/Os, power input, alarm extension, RS232 management port and external clock input are accessed from the backplane.

10/100BaseT OAM / LAN management port and LEDs indications are provided in the front of the system.

The 1.544 Mbps, T1 Interfaces are, 100 Ohms RJ-45 connectors.

Front View

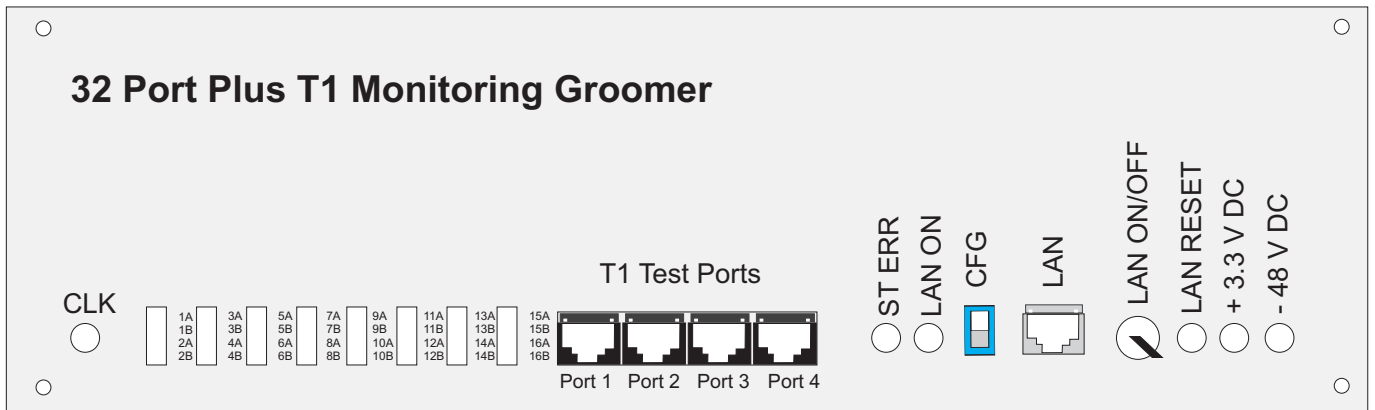

Rear View

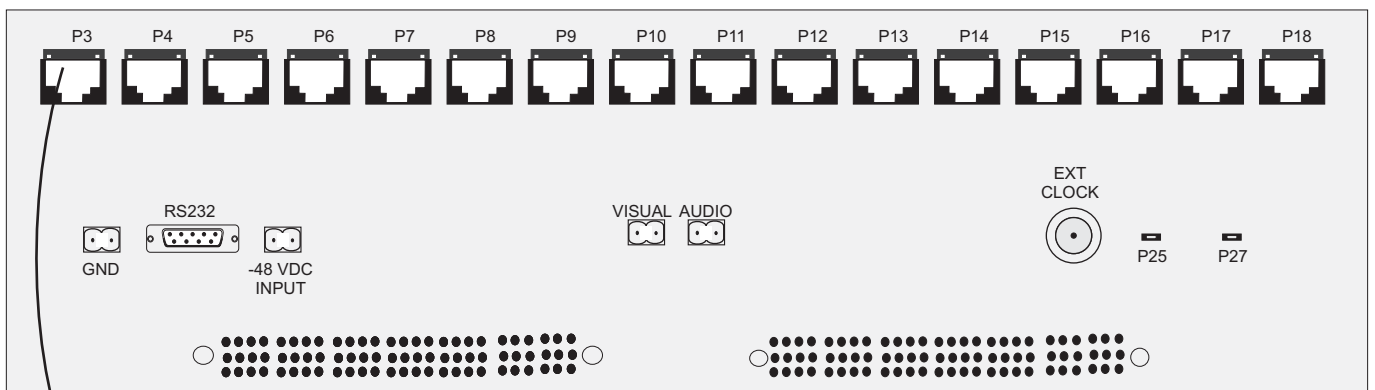

32 T1 Receivers (Monitoring Ports)

Indications and Alarm Monitoring

- Loss of incoming signal at any T1 Port
- Configuration Error Alarm
- T1 Synchronization Clock Status
- 1 to 32 T1 Ports - LED indicators to indicate the status of each T1 Monitoring Port
- 1 to 4 T1 Ports - LED indicators to indicate the status of each T1 Test Port
- 3 Volts Power Supply
- -48V DC Input Voltage present
- Configuration Error
- External alarm output - through a dry contact relay.

Programmable Features

- Specifying the priority sequence for clock selection
- Enabling or disabling T1 Ports (masking) of the T1 Ports that are not in use
- Creating a cross-connect between T1s at DS-O level (Single time-slot level) using the CLI text commands or Windows based GUI
- Telnet for remote programming.

Status Monitoring

- T1 Synchronization Clock Status
- Status of alarms
- Enabled / Disabled status of T1 Ports
- Monitoring of the VCL-MegaConnect™ 32 Port Plus - T1 Monitoring Groomer, status and configuration.

Management Options

- Telnet for remote configuration and monitoring
- Windows based GUI (Graphical User Interface) with a in-built feature to back-up and restore existing configuration files.

Technical Specifications

Monitoring T1 Ports (shall connect to the T1 links that are to be Monitored) - Monitored Port (MP)

Line Rate	T1 (1.544 Mbps \pm 50 bps)
Connector	RJ-45 (Female)
Impedance	Hi-Z for Non-Intrusive Monitoring
Compliance	G.703
Available Time-Slots	1-24
Jitter	G.823
Framing Structure	G.704
Framing Options	D4, ESF (Selectable)
Line Coding	AMI, B8ZS (Selectable)
Compliance (for Hi-Z Monitoring)	G.772
Receive Signal Sensitivity	Upto -20dBsx (0.3 Volt Pulse)
Number of T1 Receivers to connect to the Monitored Links	32 T1 Receivers. Capable of non-intrusively monitoring upto 16 T1 links bidirectionally

Test T1 Port (shall connect to the Test Equipment) - Test Port (TP)

Line Rate	T1 (1.544 Mbps \pm 50 bps)
Connector	RJ-45 (Female)
Impedance	100 Ohms
Available Time-Slots	1-24 per each T1 Port (i.e. 24x4) time-slots
Jitter	G.823
Pulse Shape Compliance	G.703
Framing	G.704
Number of T1 Ports	4

Power Supply

Power Supply	-48V DC (-40V DC to -60V DC)
Power Consumption	20 watts

DS-0 (time-slot) cross-connect capability

Any MP to Any TP through an internal non-blocking TSI Switch.

T1 Synchronization Clock options

Internal	AT&T TR62411, Telcordia GR-1244-CORE Stratum 3, Stratum 4, Enhanced and Stratum 4, ETSI ETS 300 011, ITU-T G.813 Option 1
Loop-timed	Synchronized with incoming T1 clock (MP Port clock)
External	T1, 100 Ohms - 1.544 Bit Clock

Management and Control Interfaces

- Serial Management Port (RS232) - COM Port
- 10/100BaseT for Remote Management over a LAN / TCP/IP Network.

Command Language

- Telnet - Command Line Interface (english text commands)
- Windows based GUI (Graphical User Interface).

Chassis

- 2U High
- 19-inch rack-mounting shelf.

Mechanical Specifications

Rack mounting	Standard 19-Inch. DIN Rack
Height	90.00 mm.
Depth	260.00 mm.
Width	477.00 mm.
Weight	4.00 kg

Ordering Information

S. No.	Part No.	Product Description
1	MC-32T1/4-100-MON-GROOMER	VCL-MegaConnect™ 32 Port Plus - T1 (16, "live" T1 (100 Ohms) traffic links, bidirectionally) Monitoring Groomer for non-instrusive monitoring through a high impedance (Hi-Z) with 4, additional T1 output interfaces includes: <ul style="list-style-type: none"> - System Cables - System Manual Printed Copy - System Manual CD

Technical specifications are subject to changes without notice.
Revision 15 - September 22, 2018

U.K.

Valiant Communications (UK) Ltd
Central House Rear Office
124 High Street, Hampton Hill
Middlesex, TW12 1NS, U.K.
E-mail: gb@valiantcom.com

U.S.A.

Valcomm Technologies Inc.
4000 Ponce de Leon, Suite 470
Coral Gables,
FL 33146, U.S.A.
E-mail: us@valiantcom.com

INDIA

Valiant Communications Limited
71/1, Shivaji Marg,
New Delhi - 110015,
India
E-mail: getinfo@valiantcom.com