



VCL-SafeComm-E-GE

1+1 Automatic Ethernet Failover / AB / Fallback Switch
- *the alternate network solution*

Data Sheet

Product Overview

VCL-SafeComm-E is a family of Ethernet Failover Protection Switches that provide 1+1 Automatic Ethernet Failover / AB Fallback Protection between an "active" and "standby" equipment; or between "main" and "standby" networks which are connected to the network through an Ethernet interface.

VCL-SafeComm-E-GE - 100/1000BaseT Gigabit Ethernet Failover (19 Inch Rack Mount) unit which supports a maximum of 1000MBits/sec. data throughput on its primary and standby interfaces. The VCL-Safecomm-E-GE – 100/1000BaseT Fast Ethernet Failover (19 Inch Rack Mount) unit features 1+1 redundant power supplies.



Number of interfaces available in Gigabit Ethernet version: Three

- 1 x 100/1000 Gigabit Ethernet Interface: Network A (Primary)
- 1 x 100/1000 Gigabit Ethernet Interface: Network B (Standby)
- 1 x 100/1000 Gigabit Ethernet Interface User (Protected)

1+1 AC or DC power supply available in 19 Inch Rack Mount version.

Use Case # 1: The VCL-Safecomm-E-GE, Ethernet Failover equipment provides 1+1 Automatic Ethernet Failover Switching / Fallback Protection between two, Main and Standby Switches, Servers, RTUs or any other similar terminals to provide equipment redundancy in applications which require 99.99% terminal equipment up-time. The Ethernet 1+1 fail-over protection automatically switches to the "standby" terminal equipment in the event of failure of the "primary" terminal equipment to ensure that the 99.99% terminal equipment up-time requirements are always being met.

Use Case # 2: The VCL-Safecomm-E-GE, Ethernet Failover equipment provides 1+1 Automatic Ethernet Failover / AB Fallback Switch provides protection between an "active" and "standby" IP / Ethernet / MPLS Networks (including "active" and "standby" Gateways and Routers) to provide 1+1 automatic ethernet fail-over protection between two distinctly separate networks through an ethernet interface.

Features and Benefits

- Fail-Safe. Never becomes a point of failure. Automatically reverts to and reconnects to the "primary network" / even in a power down condition.
- End-to-End network Link monitoring
- User configurable link test parameters.
- User configurable switching parameters.
- Built-in real-time clock (RTC) / real-time logging maintains a history of all events.
- Serial Management Interface (USB) for local access.
- Remote access over TCP-IP networks. Allows the user to access and carry out maintenance, or / and switch the links remotely, if required
- Password Controlled Access. Maintains a complete log of all logins.
- Script Assisted Switching. Automatically initiates switching upon receipt of the scripted message / SNMP Trap.
- Switching initiated through external triggers such as "Dry Contact Alarm Relays".
- Manual Switching through front-panel buttons automatic front panel locking to prevent accidental switching.
- The data connection through the VCL-Safecomm-E-GE between the local area network and the WAN is completely transparent. The VCL-Safecomm-E-GE is a simple failover switch and does not provide any data routing between its data ingress and data egress ports.
- SNMP Management and Monitoring, SSH, NMS, Syslog.

Applications

- Enhances network availability and reliability.
- Eliminates network downtime by automatically / seamlessly switch to the "backup" / "standby" network in the event of the complete and total failure of the primary/ active IP network.
- Disaster Recovery. To provide automatic failover protection in mission critical applications requiring minimum downtime.
- To switch between and automatically re-route IP traffic to the "standby" network upon the failure of the "primary" transmission network. simultaneously for "end-to-end" network availability.
- Alerts the user upon the failure of any one of the two "active"/"primary", or "secondary"/"standby" IP transmission network.
- Enhances availability and reliability.
- Eliminates network downtime by automatically / seamlessly switch to the "backup" / "standby" equipment / network in the event of the complete and total failure of the primary/ active equipment / IP network.
- May also be used in combination with VCL-Firewall to provide firewall redundancy, enhanced security and resilience to hostile such as "DoS" (Denial of Service) and "Hack" attacks.
- VCL-Safecom-E-GE may be used to provide automatic fail-over protection and switching across diverse IP domains such as fiber-radio; or fiber-satellite (VSAT); or fiber-PSDN (public switched data network).
- Automatic Link Test Feature. Concurrently tests both "active" and "standby" IP links, for "end-to-end" network availability.
- Alerts the user upon the failure of any one of the two "active" / "primary", or "secondary" / "standby" IP transmission network.

User programmable criterion for switching between Primary and Standby (Protected) Networks

- Automatically switches between "active" and "standby" networks upon failure of the "connected" network.
- Completely eliminates the need to move (reconnect) cables. Automatically re-routes the traffic to the "available" network.
- Failsafe: Never becomes a point of failure. Automatically reverts to and reconnects to the primary link even in power down condition.
- Switching criterion is completely user programmable.
- Automatic Failover Switching criterion includes:
 - Loss of Signal
 - Loss of Link; Loss of end-to-end link connectivity
 - Heartbeat; Script (Message) based switching
 - User programmed timed switching based upon "Wall-Clock" (Time of Day)
 - Triggers generated by external dry contact relays of connected equipment
 - Packet counters (Unicast, Multicast and Broadcast) based switching
- Manual Failover Switching:
 - Manual Switching through front-panel buttons with automatic front panel locking to prevent accidental switching.
 - Manual switching through CLI command.

Shelf Description

- The Ethernet Failover Switch is available as a 19-inch 1U shelf that provides access to all external interfaces.
- 1+1 Redundant power supplies.
- User and Network side Ethernet Interfaces, Access and Management ports (USB and 10/100BaseT Ethernet interfaces), external alarm outputs and external (alarm inputs) trigger connectors.

VCL-SafeComm-E-GE providing and reliability:

1. Provides 1+1 Network / Link Protection
2. Failsafe: Never becomes a point of failure. Automatically reverts to the primary link even in power down condition.
3. End-to-End network Link monitoring
4. Fast automatic network switching upon network failure. Eliminates Network Downtime.
5. Completely eliminates re-routing of Ethernet cables. Ethernet cables are automatically moved to the available network port.
6. Essential for any application that requires 1+1 Network / Link / Path redundancy including small / medium office establishments, PoS (point-of-sale) equipment, banking establishments, hotels, ATMs, smaller Industrial Installations etc., requiring minimum service interruption due to network outage.
7. Disaster Recovery.

Switching parameters include:

- Network Interface(s) go down. Loss of signal on the network interface.
- Gateway(s) (Routers) go down and the routers(s) are unreachable.
- External triggers (such as the closing of an external alarm relay of your either of your routers). The user may use / may not use this option.
- Script assisted switching (and SNMP trap generated by any one of your routers to initiate switching due to router / network failure). The user may use / may not use this option.
- The actual network to become unreachable. This is done by programming a network target IP address in the VCL-Safecomm-E-GE. The network target IP address is the last point (or an omnipresent point) in a network that can be programmed by the user which can be a Google DNS server (such as 8.8.8.8), or user's corporate server (such as 161.170.140.127), if you are working in protected VPN. If, in the event, the connectivity between VCL-Safecomm-E-GE and the user programmed network target IP address is lost through the "primary" network / route, the VCL-Safecomm-E-GE automatically switches to the "standby" network / route.
- Packet counters (Unicast, Multicast and Broadcasts) based switching.
- All switching events are time-stamped and logged in VCL-Safecomm's non-volatile memory. The logs may be viewed by the network administrator at any time for network quality analysis.
- Recovery / fallback parameters to the primary route / primary network is also user programmable. These can be "automatic recovery to the primary network" upon the restoration of the primary route / primary network, or upon the failure of the standby / alternate network. One note to add here is the VCL-Safecomm-E-GE simultaneously tests both active and standby routes so the system is always aware of the status of both networks. Switching to a "dead" route shall never occur under any condition.
- The data connection through the VCL-Safecomm-E-GE between the local area network and the WAN is completely transparent. The VCL-Safecomm-E-GE is a simple failover switch and does not provide any data routing between its data ingress and data egress ports.

Technical Specifications

Specifications:

Number of Ethernet Interfaces	3
Interfaces	1 x 100/1000 Gigabit Ethernet Interface: Network A (Primary) 1 x 100/1000 Gigabit Ethernet Interface: Network B (Standby) 1 x 100/1000 Gigabit Ethernet Interface User (Protected)
Guaranteed Maximum Data Throughput	1000 Mbps on 1000 Mbps connection
Interface Type	10/100/1000 BaseT-X
Conformity	IEEE-802.3

Management and Control Ports:

- Serial Management Port - USB, RS232
- 10/100 BaseT for remote management

NMS (with Telnet) Specifications:

OAM Network Interface	RJ-45 Ethernet, 10/100BaseT
Compatibility	Ethernet Version 2.0 IEEE802.3
Monitoring and Management	Serial login, Telnet, SSH (With option to disable clear text login for users).

AC Power Supply Specifications:

Range of input AC	90V~240V AC, 50Hz / 60Hz. Voltage
-------------------	-----------------------------------

48VDC Power Supply Specifications:

Input DC voltage - Dual Input	48V DC (nominal)
Range of input voltage	18V to 72V DC
Input voltage reversal Protection	Provided in the system
Short circuit protection	Provided in the system

110VDC~220VDC Power Supply Specifications:

Input DC voltage - Dual Input	110VDC or 220VDC (nominal)
Range of input voltage	85VDC to 290VDC
Input voltage reversal Protection	Provided in the system
Short circuit protection	Provided in the system

Power Supply Options:

- AC power (90 to 240V AC, 50/60 Hz)
- DC Power 24VDC; 48VDC; 110VDC; 220VDC

Power Consumption:

- < 10W at ambient (steady state 24°C)

Local / Remote Management and Monitoring Ports:

- USB
- 10/100BaseT Ethernet, RJ45
- 2 x External Alarm Trigger Inputs
- 1 x Dry Contact External Alarm Relay Output

Local / Remote Communication Options:

- Telnet / SSH (option to disable clear text communication to comply with NERC security requirements)
- CLI Control Interface (HyperTerminal or VT100)

Security and Protection:

- Password Protection with password strength monitor
- SSH

Environmental (Equipment):

Operational:	-10C to +65C (Typical: +25C)
Cold start	0C
Storage	-20C to +70C
Humidity	95% non-condensing
Cooling	Convention Cooled. No cooling fans are required.

Mechanical Specifications:

Height	44 mm (1U)
Width	480 mm (DIN 19-inch)
Depth	225 mm
Weight	3.5 Kg
Rack Mount	19" Rack mounting

Command Language:

- English text commands
- Graphical User Interface (GUI) - English

MTBF and Equipment MTBF:

- Never becomes a point of failure
- Per MIL-HDBK-217F: ≥ 37 years @ 24C
- Per Telcordia SSR 332, Issue 1: ≥ 42 years @ 24C

Compliance:

- EMC FCC Part 15 Class 2
- Operation ETS 300 019 Class 3.2
- Storage ETS 300 019 Class 1.2
- Transportation ETS 300 019 Class 2.3

Application Diagrams :

To provide 1+1 Network Protection - Explained

Ethernet link is connected to Network A

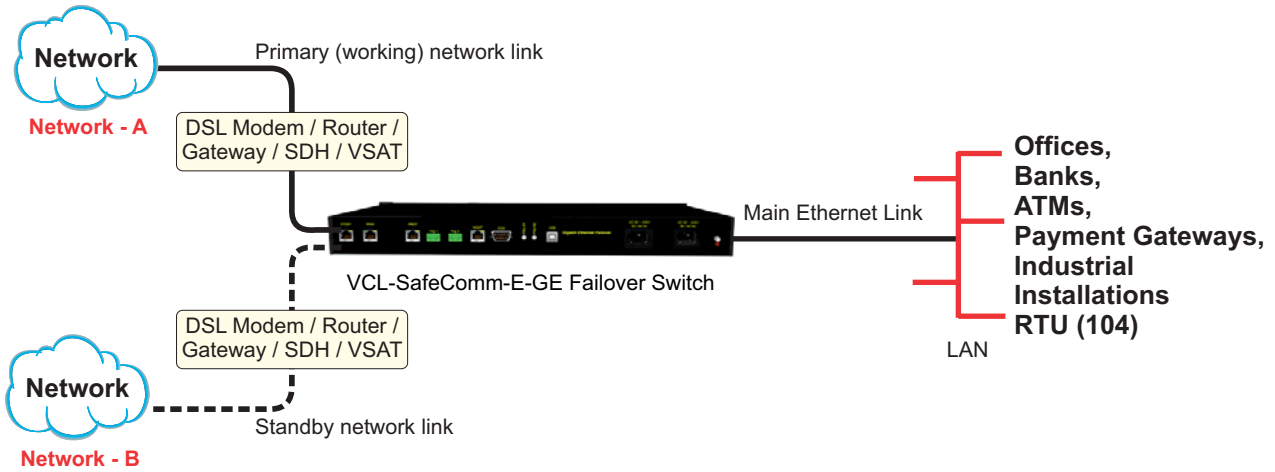

Network A fails. Ethernet link automatically switches to Network B

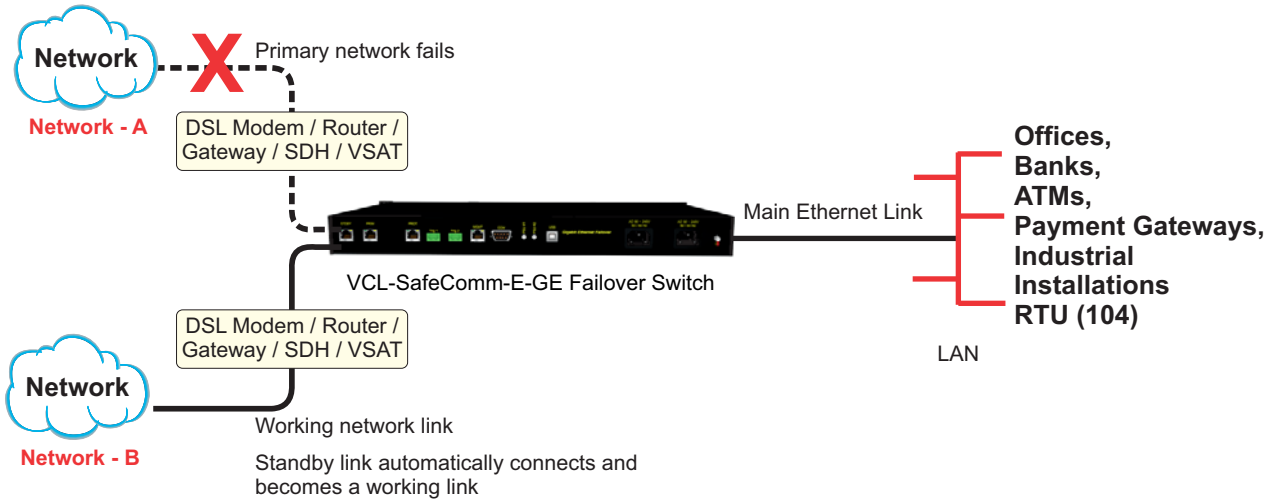

Network A recovers - Ethernet link automatically reverts and reconnects to Network A

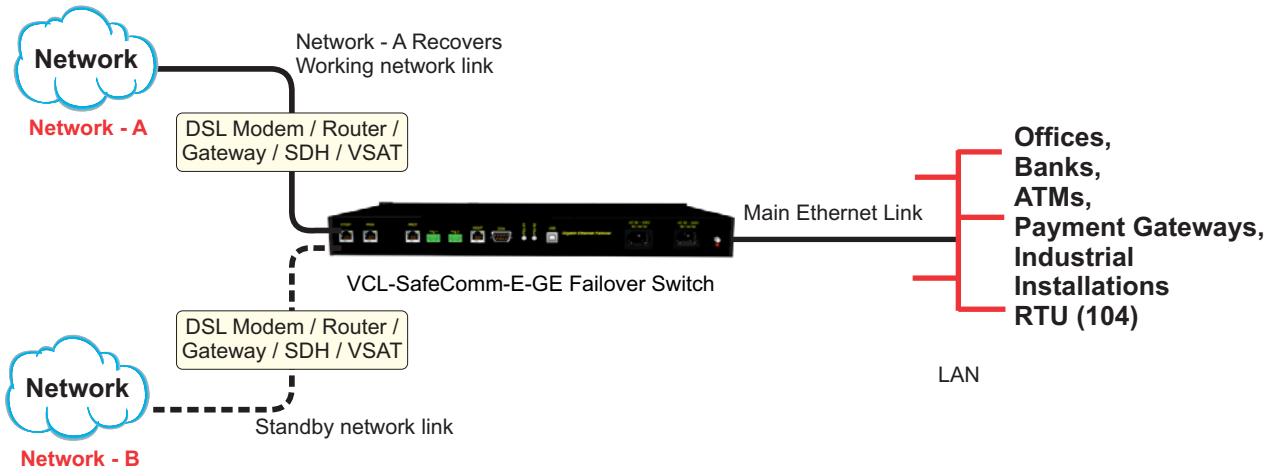

Application Block Diagram #1 (monitoring internet connectivity)

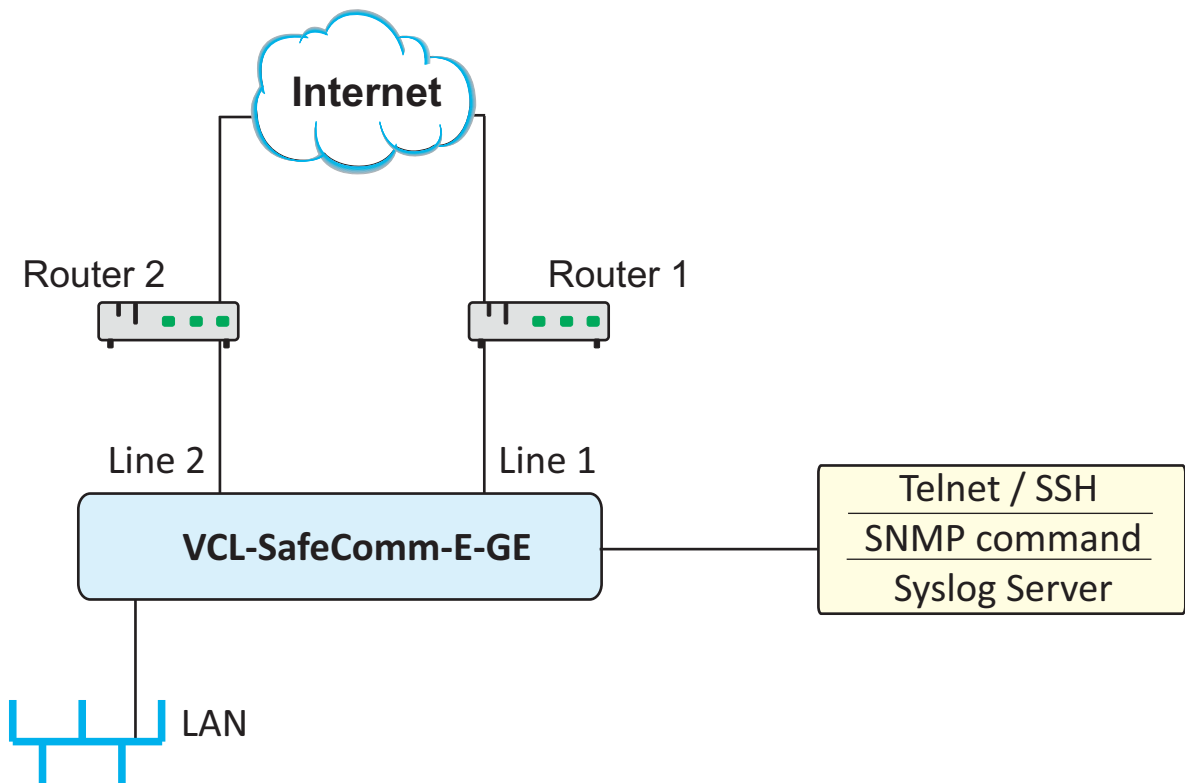

Application Block Diagram #2 (monitoring enterprise server)

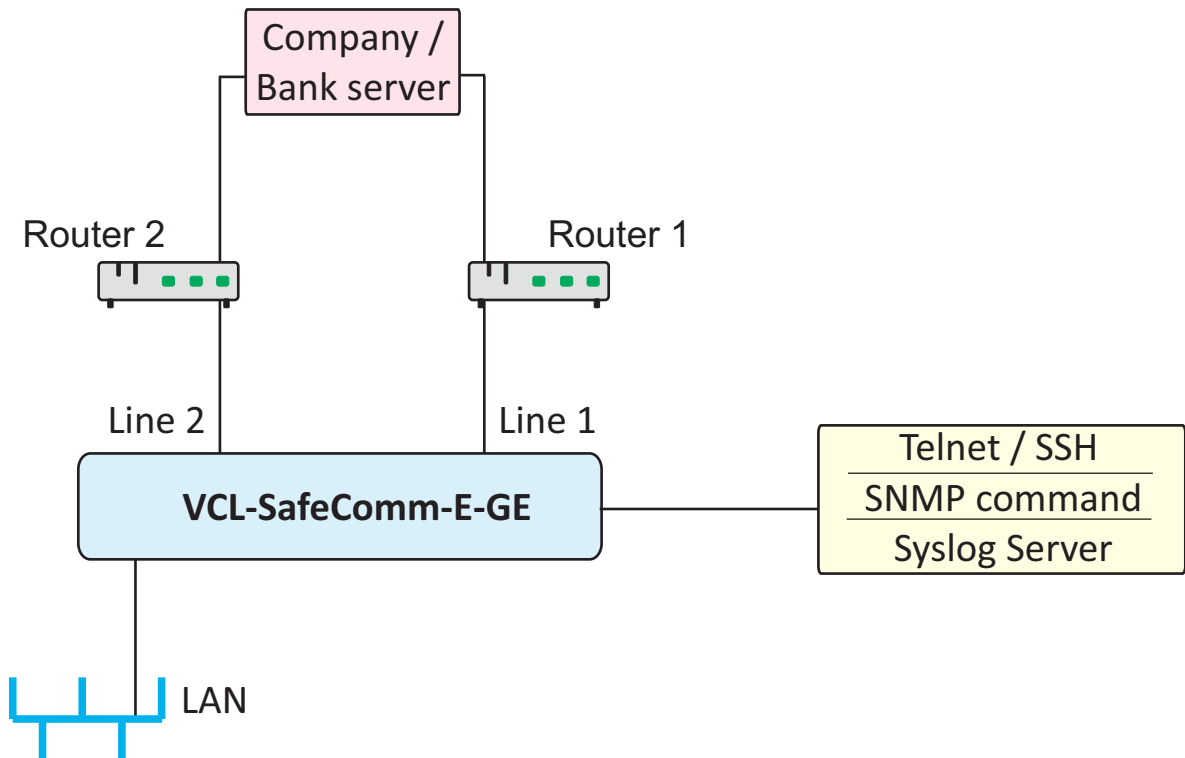

Ordering Information: VCL-SafeComm-E-GE, 1+1 Automatic Gigabit Ethernet Failover / AB / Fallback Switch

Core Unit without PSUs

S. No.	Part No.	Product Description
1	VCL-SafeComm-E-GE-2778	Gigabit Ethernet Failover Switch <ul style="list-style-type: none"> - Provides 1+1 Automatic Ethernet Failover Protection between two (Main and Standby) Ethernet Switches, Gateways, Terminals, Servers, Routers, RTUs, etc - 19-inch, Rack Mount Supports: <ul style="list-style-type: none"> - 3 x Gigabit Ethernet [1000Mbps RJ45 (F)] [1 for Network A, 1 for Network B, 1 for User] - Management: SNMP, Telnet (RJ45 (F) Port), Serial Port (USB, DB-9 COM), EMS, Graphical User Interface (GUI) - Installation Kit: System Core Cables, Mounting Hardware, Documentation, User Manual *Add Power Supply Option from below

*Add Power Supply Options

1	ACDC	1 x 90-240V AC Power Supply Input 1 x 48V DC Power Supply Input
2	AC220R	2 x 90-240V AC Power Supply Input [Redundant]
3	DC048R	2 x (-) 48V DC Power Supply Input [Redundant]
4	DC220R	2 x 110-220V DC Power Supply Input [Redundant]

Technical specifications are subject to changes without notice.

All brand names and trademarks are the property of their respective owners.

Revision 2.7 – March 26, 2022

U.K.

Valiant Communications (UK) Ltd
Central House Rear Office
124 High Street, Hampton Hill
Middlesex, TW12 1NS, U.K.

E-mail: gb@valiantcom.com

U.S.A.

Valcomm Technologies Inc.
4000 Ponce de Leon, Blvd.,
Suite 470, Coral Gables,
FL 33146, U.S.A.

E-mail: us@valiantcom.com

INDIA

Valiant Communications Limited
71/1, Shivaji Marg,
New Delhi - 110015,
India

E-mail: mail@valiantcom.com